

## HIT Pendulum Impact Testers from 5 to 50 Joule

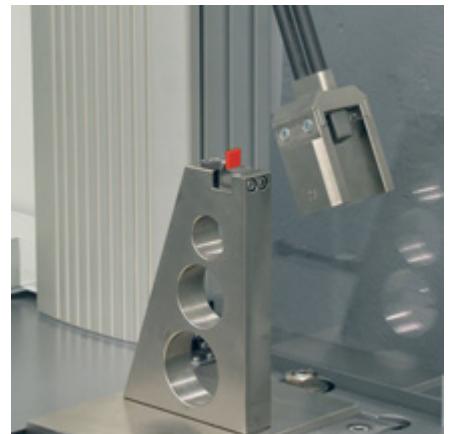
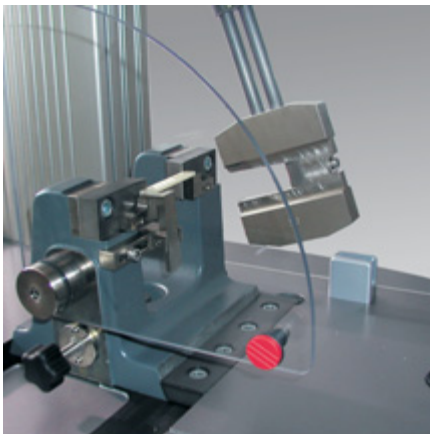
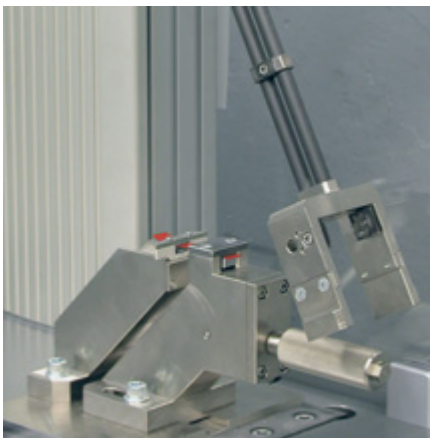

Intelligent Testing

## 1. The Pendulum Impact Testers from Zwick are a HIT

### Important Characteristics

Leading mechanical testing products manufacturer Zwick Roell Group's HIT Pendulum Impact Testers are benchmark instruments for plastics manufacturers and processors

Accuracy, dependability and ergonomic design are primary features of the HIT pendulum impact testers. Advanced manufacturing technology brings improved accuracy specifications, with the following innovations and benefits for users in both R+D and quality assurance:

- Pendulum coding as standard  
The HIT Pendulum Impact Testers automatically recognize the pendulum being used and evaluate the test values in the correct range corresponding to the relevant standard. This ensures that different pendulum sizes or test procedures are used correctly, eliminating troublesome, error-prone fitting of additional pendulum masses as used by some pendulum impact testers.
- Virtually vibration-free  
A world innovation is the use of double carbon rods for the pendulums, providing a high level of stiffness in the direction of impact and a strong concentration of the mass at the impact point. Compared to conventional single-rod, metal construction pendulums or compound type pendulums, the energy loss due to resonant oscillations is considerably reduced. The high stiffness level gives the pendulums excellent dynamic characteristics and prevents excessive forces in the pendulum rod during operation, for example if Izod specimens are only partially broken.

- Tool-free pendulum change  
Each pendulum is equipped with a quick change unit, allowing changing of pendulums to be carried out quickly without special tools. Significantly there are no mounting components which can be easily lost with a resulting change in pendulum energy.
- Low-wear disc brake  
The optional pendulum disc brake is virtually wear-free.
- Ergonomic design  
Important operating elements such as keyboard, brake, release lever and display are all at one level within easy reach of the operator.
- State-of-the-art electronics  
The new control electronics contain a high resolution digital encoder for precise measurement of the impact angle. For integration into laboratory management systems an RS232 interface is included. PC connection is via a USB upstream interface.
- Pendulum instrumentation  
Instrumented pendulums and add-on electronics are available and provide a high-precision record of the rapid sequence of specimen impact and fracture. Each of these pendulums uses Zwick's plug and play sensor connection system.
- High performance PC-Software *testXpert*® II (optional) offers evaluations to DIN, ISO and ASTM. Reports and data archiving are performed in normal Windows® formats.



Fig. 1: HIT5P with Charpy fixture,

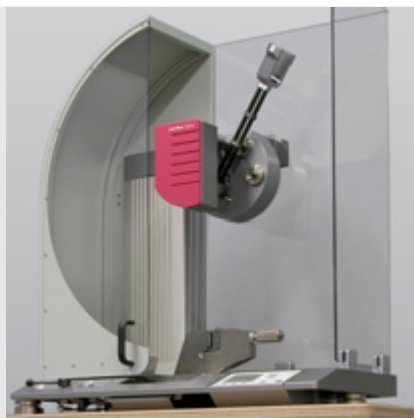

HIT5.5P with Izod fixture,



HIT50P with safety housing

## 2. HIT Pendulum Impact Testers – Everything a Pendulum Impact Tester Needs

### Models available

HIT pendulum impact testers are available in two versions:

- **Stand Alone model**

This model is the ideal choice when there is no need to store test data. The results are calculated by the pendulum impact tester and can be displayed as required as absorbed impact energy, or as a percentage of the pendulum's potential energy. A large, clear display allows reliable result reading, even at a distance.

- **PC model**

The PC model with RS232 or USB interface is the perfect choice if test results are to be stored and/or subsequently processed. The *testXpert® II* testing software takes the test data and prepares it graphically and statistically. If an electronic vernier caliper is connected to the PC, the impact area of the specimen can be measured, transferred to the PC and the impact strength determined. Data link to laboratory information systems are also possible.

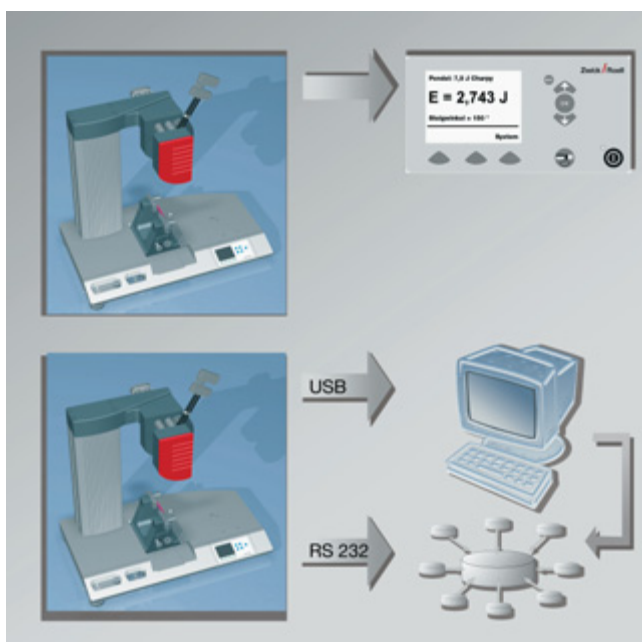

Fig. 1: HIT Stand Alone PC models

### Low vibration instrument design

The systematic design of the perfect low-vibration pendulum impact tester begins with the items closest to the specimen - the pendulum and the supports.

For this reason we use high-performance carbon materials for the HIT pendulums. This significantly increases the stiffness of the pendulum, brings the distribution of its mass very close to the ideal pendulum and makes both instrument and results more reliable and robust over the long term.



Fig. 2: Low vibration carbon pendulum rod

The ratio of pendulum to frame mass is extremely high, and enables it to measure 80 % of consumed energy with high accuracy according to ISO 13802.

A unique feature of the HIT pendulum impact testers is the dovetail base plate guide which secures the Charpy, Izod, and tensile impact fixture over the entire depth of the support. Whilst enabling the tester to be quickly setup for each type of test, it also guarantees a perfect connection between the fixture and the frame of the impact tester.

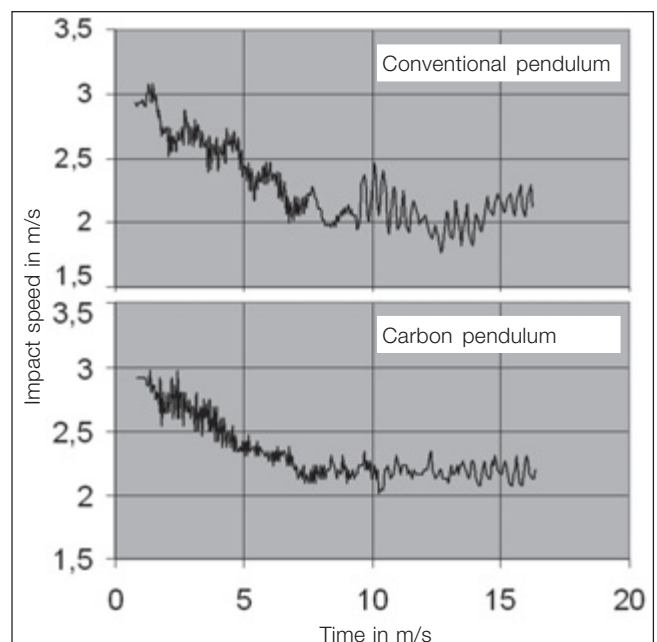

Fig. 3: Reduced inherent vibrations carbon pendulum

These outstanding features earned HIT pendulum impact testers the Materialica 2006 Design Award.

The heavy frame is made of cast iron to dampen vibrations, and three heavy-duty locking leveling-feet ensure that the HIT remains perfectly level.

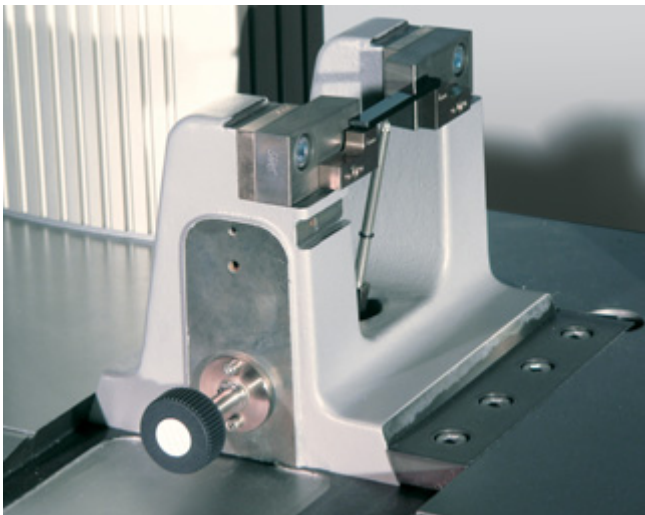

Fig. 1: Charpy fixture showing large mounting face and clamping wedge

An optionally available table has been specifically designed to ensure optimum operating conditions for the HIT range.

Reliable test results can now be achieved regardless of local conditions. Large-area leveling elements and positioning stops provide a firm base for the pendulum impact tester. With Izod tests, the specimen remains fall directly from the support into a tray, so that they can be disposed of efficiently.

The testers can of course be positioned on any table possessing adequate lateral stability.

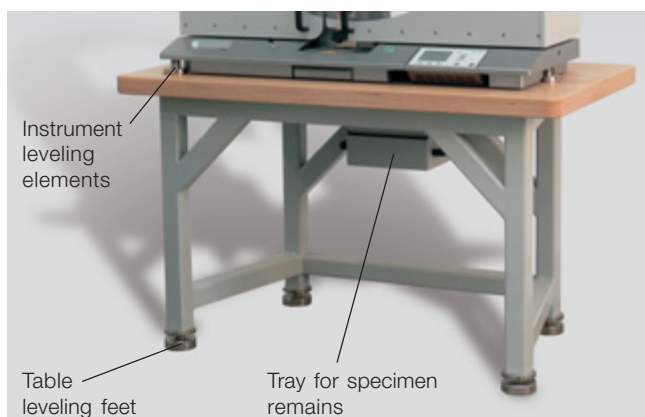

Fig. 2: Instrument table for the HIT pendulum impact testers

## Motorised pendulum return

After the test the pendulum is automatically captured and returned to the starting position. This feature enables the starting angle setting to be varied and optimum test parameters such as impact speed and energy loss on impact to be determined.

## Pendulum identification and interchangeability

Just as a certified weight has its mass engraved, each Zwick pendulum carries its own data in its electronic pendulum coding (Fig. 3).



Fig. 3: Electronic pendulum coding

The pendulum's test type and standard, energy, starting angle and other physical data are identified electronically, eliminating erroneous measuring.

Precision manufacture ensures that test results exceed the requirements of international standards. Pendulums can therefore be freely interchanged between HIT instruments with the same maximum energy rating.



Fig. 4: Pendulum quick release

## Instrumentation

With instrumented testing, the load during impact is measured using piezo load cells or strain gages, depending on the individual case. The raw values are in the form of a load-time curve.

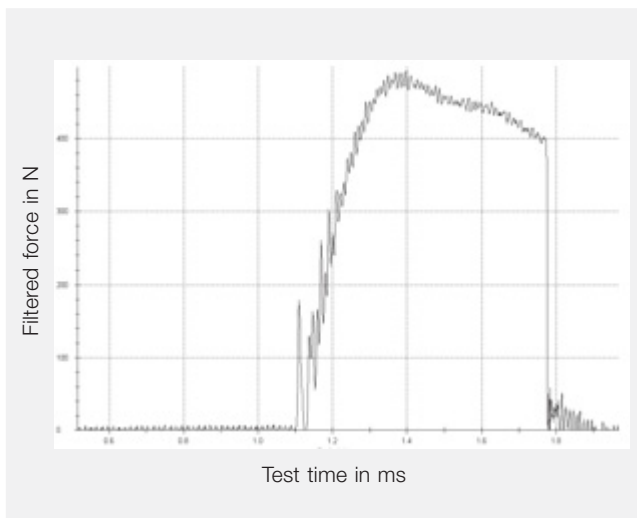

Fig. 1: Load-time curve

Instrumented Zwick pendulums in use are identified via the sensor plug and all associated parameters (e.g. tup calibration data) are set correctly. This provides the user with straightforward handling, a high level of flexibility and maximum measuring reliability, as no further operator intervention is required for hardware or software.

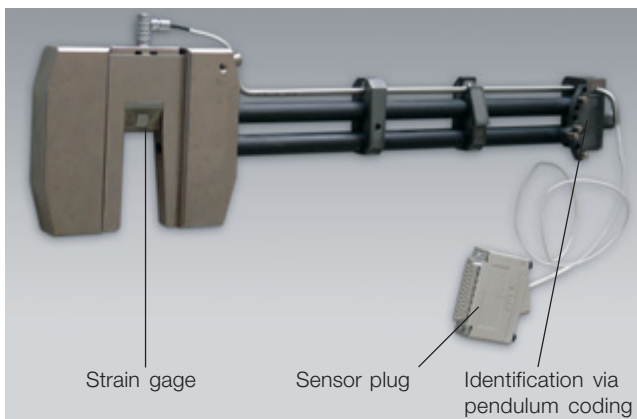

Fig. 2: Instrumented Charpy pendulum

## Modern instrument electronics

The electronics perform all important functions: the calculation and display of impact energy, the standard-compliant correction of windage and bearing friction and monitoring the vertical position in the impact direction.

PC connection except with the Stand Alone model, is via a USB interface. There is also a serial interface for connection to existing LIMS systems.



Fig. 3: Clear, easy-to-read operating panel

A wide input range allows easy connection of the HIT range to any mains supply in the world.

Simple, intuitive operation is a feature of HIT electronics with the individual steps subdivided logically from set-up to test definition. The menu leads quickly from set-up to test mode. Set-up includes:

- Standard-compliant determination of bearing friction and windage and input of local rate of acceleration due to gravity.
- Monitoring pendulum oscillation period.

Displayed in test mode:

- Absorbed impact energy in joules or in ft-lbf and as a percentage of potential pendulum energy.

Measuring the impact resistance requires the use of a PC, to which a digital measuring instrument (vernier caliper, micrometer) can also be connected and used to determine the dimensions of the specimen.

## Specimen conditioning

A magazine and tempering box are available from Zwick.



Fig. 1: Specimen-conditioning box

Conditioned specimens must be impacted within 5 seconds of being removed from the tempered area. Tempering magazine holders with specimen magazines provide a quick test sequence for the HIT pendulum impact testers. Specimen magazines with magazine carriages for different specimen dimensions are attached directly to the pendulum impact tester as are the magazine holders.

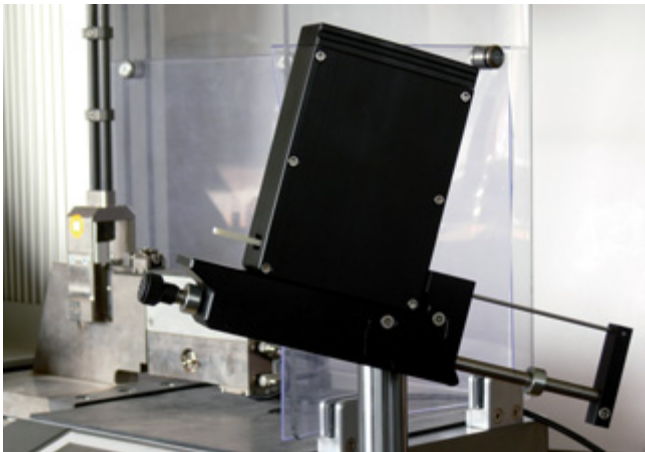

Fig. 2: Magazine with chilled specimen

## Ergonomics

Packed with outstanding ergonomic features, the HIT pendulum impact testers offer significant advantages to testing laboratories. The machine controls are placed close together and at the same level helping to simplify operation and reduce operator fatigue.

Fixtures can be replaced simply by loosening the retaining screws, removing the existing fixture, and inserting the new one. Exact positioning is achieved via stops in the baseplate.

The pendulum is easily changed by means of a quick release mechanism, eliminating the need for tools.

The optional safety protection system incorporates an integral collecting tray on the left side for specimen remains and can be emptied by swivelling the shield out.

The electronics feature a simple and easy-to-use keyboard, with a large, clear display designed to reduce fatigue even when testing large batches. The structured menu system makes operating the instrument quick and easy.

## Application range and standards

HIT pendulum impact testers can be used for the determination of impact resistance on plastics, metals and other materials and can be equipped with accessories for Charpy, Izod, Dynstat, and impact tensile testing in accordance with the following standards:

Method	DIN	ISO	ASTM
Charpy	50115	179-1	D 6110
		179-2	
Izod		180	D 256 (notched) D 4812 (un-notched)
Impact tensile		8256 A	D 1822 (spec. in head)
		8256 B	
Dynstat	53435		
	51230		

## Accessories

### Operator protection

The HIT pendulum impact testers can be equipped with modular safety devices. Certain legal safety standards allow working without protection shields up to a pendulum energy of 5.5 joules. Above this value operator protection is required.

The safety device contains an integrated receptacle for catching the specimen remains. If the safety device is swiveled out, the specimen remains can be easily and quickly removed.

The instrument therefore conforms to CE-requirements for impact energies > 5.5 joules and DIN 51233 (Materials Testing Machines – Safety Specifications).

The HIT25P / HIT50P pendulum impact testers (PC version with pendulum return) are equipped with a safety housing. This housing is also optionally available and is recommended where specimen debris might be ejected from the testing system after impact.

A local operator shield is available for the Charpy fixture to protect the operator from flying debris (Fig. 3)

In the interests of safety the HIT25P and HIT50P are equipped for two-handed operation and have safety devices to left and right.

## testXpert® II PC-Software

A choice of Master and Standard Test Programs are available for the HIT pendulum impact testers.

Master Test Programs have a comprehensive range of options and flexibility to control test parameters and process results, and are perfectly suited to research and development needs.

Standard Test Programs are focused on individual DIN, ISO and ASTM Standards, and are designed primarily for use in quality control laboratories.

Main features of Standard Test Programs:

- Determination of impact characteristics according to Standard
- Terminology according to Standard
- Generate test curve showing impact characteristics over time and number of specimens. Generation of test curves over force and time or over force and travel are possible in instrumented testing
- Perform discrete statistical evaluations according to differing specimen fracture behaviour

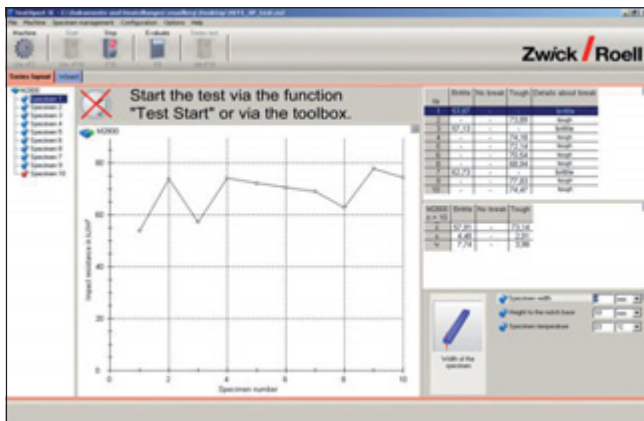

Fig. 1: testXpert® II Standard Test Program

Main features of the Master Test Program:

- Determination of impact characteristics according to Standard
- Generate test curve showing impact characteristics over time and number of specimens and temperature
- Perform statistical evaluations
- Independent report creation and data export
- Option for determination of the failure mode is available

## Charpy fixture

The Charpy fixture comprise a heavy cast iron base. Test-specific accessories such as supports and anvils are selected according to the specimen to be tested (Fig. 2).

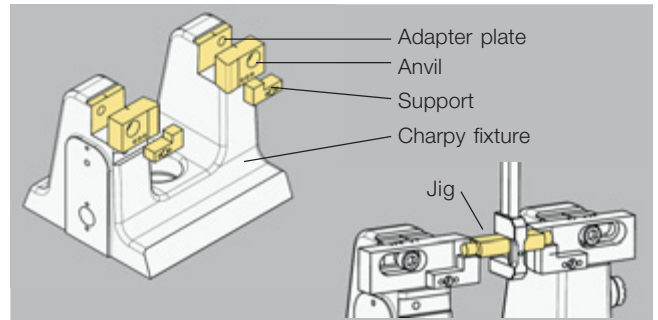

Fig. 2: Principle of Charpy fixture with accessories

The surface finish and radius of the anvils used can significantly affect the accuracy of the test results. Zwick anvils are fully precision CNC manufactured and checked for 100% dimensional accuracy. We do not supply one-piece anvils, as these may have low dimensional accuracy.

Anvils can be replaced individually, making spares ordering easy and cost-effective.

An optional jig ensures the anvils are accurately positioned relative to the tup.

As anvils are subject to greater wear than supports they are designed to be easily and inexpensively replaced independently of the supports or adapter plates.

Quick-change adapter plates are used to adapt the pendulum impact tester to different specimen widths. Different specimen (vertical) dimensions are accommodated by using appropriate sized Charpy supports precisely positioned via set pins.



Fig. 3: Notch alignment unit on Charpy fixture

The quick change adapter plates are used to adapt the pendulum impact tester to different specimen widths, whilst the supports are precisely positioned using set pins and adapt to the specimen thickness.

An optional swivelling protective shield can be used with the fixture, and a positioning aid helps to locate the specimen correctly, using either the notch or the front edge of the specimen.

Advantages:

- Quick changing of Charpy fixture
- Anvils precision-made by CNC machine and individually inspected for 100% accuracy

## Izod fixture

Two types of Izod fixtures can be used: The manual fixture clamps the specimen via a fine-threaded lead screw, ensuring optimum gripping force is applied, whether to sensitive, soft or hard specimens.

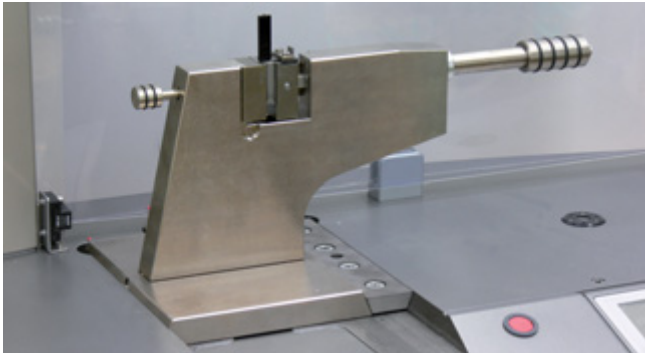

Fig. 1: Izod fixture with manual operation

The pneumatic vise is ideal if a high through-put is to be achieved, or if temperature conditioned specimen are to be tested. A further advantage is its high clamping force reproducibility, which leads to excellent test results on materials which are sensitive to clamping forces.

Quick clamping via a switch on the fixture minimizes the time between removing the specimen from the temperature unit and the performance of the test.

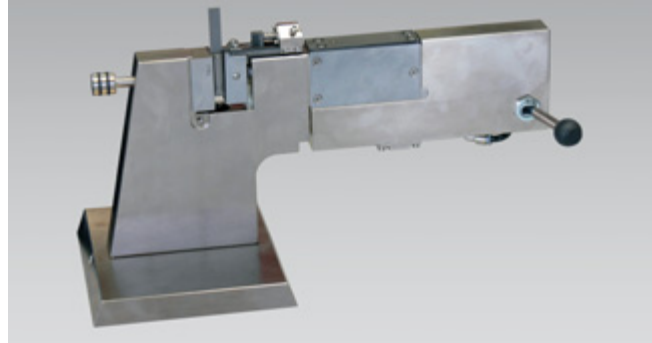

Fig. 2: The clamping force is reproducible with the pneumatic operated Izod fixture

Both fixtures are equipped with a centering unit which ensures that the specimen is always positioned at notch root level. Positioning of the sample relative to its width in the impact direction is achieved via quick-change inserts with lateral guides.

Advantages:

- Quick centering and gripping of specimen
- Fine adjustment of specimen clamping force
- Quick testing using the pneumatic fixture
- High test result reproducibility due to the constant clamping force

## Tensile-impact fixture

Specimen and yoke are assembled in a jig. Depending on the testing method being used, the specimen and yoke are clamped in either the pendulum or the tensile impact fixture.

For ISO and ASTM specimens corresponding templates can be selected.

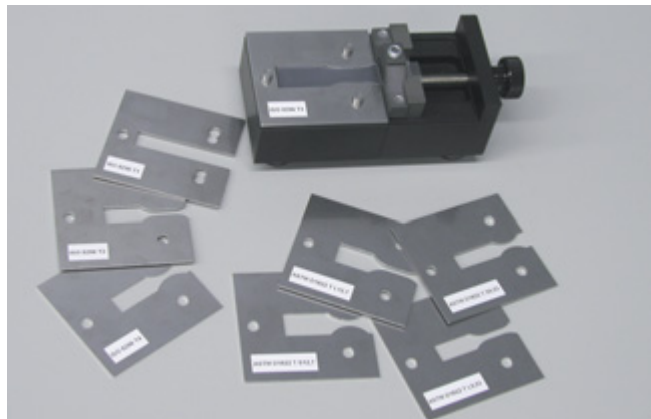

Fig. 3: Clamping jig and templates for the tensile impact test



For tests according to ISO 8256, Method A one specimen shoulder is gripped a yoke. The other end of the specimen is clamped in the tensile impact fixture. The pendulum strikes the yoke and creates a tensile impact on the free end of the specimen. Yokes with masses of 15 up to 120 g are available.

For tests according to ISO 8256 Method B and ASTM D 1822, one specimen end is gripped in the pendulum. The other end of the specimen carries a yoke and hangs free. During the test, the free end with the yoke strikes the tensile-impact fixture.

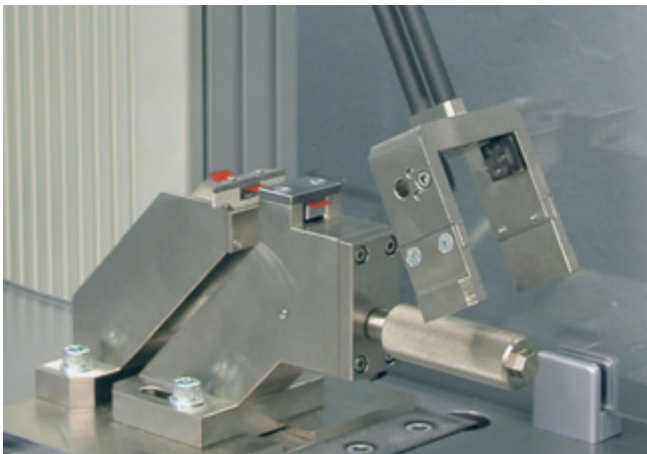

Fig. 1: Fixture for tensile impact tests, Method A

A fixture and yokes from 15 g up to 120 g are available for each Standard.

Advantages:

- Rapid configuration changes between the two different test methods.
- Precise sample alignment and clamping

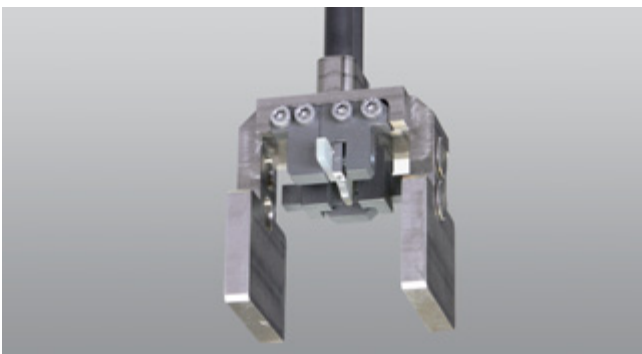

Fig. 2: Tensile impact specimen in pendulum - ASTM D 1822

## Dynstat fixture

The HIT pendulum impact testers can also be equipped for Dynstat tests to DIN 51230. A Dynstat fixture and a comprehensive range of pendulums cover the Dynstat applications.



Fig. 3: Dynstat fixture

## Specimen preparation

### Automatic notch cutting machine

The Zwick ZNO notch cutting machine is used to notch plastic specimens in accordance with the standards ASTM D 256, ASTM D 6110, EN ISO 179, EN ISO 180, and EN ISO 8256 (Charpy and Izod tests).

Studies have shown that the direct positioning of the notch and its dimensions have an influence on the energy measured. Therefore, correct notching is of high importance. The combination of solid construction and safe and easy handling make the Zwick notch cutting machine the ideal tool for making notched specimens from any type of plastic material.



Fig. 4: Notch cutting machine Zwick ZNO

### 3. Instrument Specification HIT5P

The following points should be checked before a pendulum impact tester is specified in detail:

- To be used with or without a PC
- Standards to be used
- Test methods and specimen to be used

The specification guide on the following pages is designed to help you to configure your instrument to meet your testing requirements. Naturally, we will be happy to answer any questions that may arise.

For a quick orientation we marked the item numbers with a red dot (•).

#### Selection of the basic instrument HIT5P

	PC model	Stand Alone model
	to be used with PC	to be used without PC
Max. impact energy	5 J (3.69 ft-lb)	5 J (3.69 ft-lb)
Impact velocity	2.9 m/s	2.9 m/s
Width x Height x Depth	680 x 685 x 404 mm	680 x 685 x 404 mm
Weight without accessories	approx. 75 kg	approx. 75 kg
Test results, numeric	impact energy [%], impact energy [J] impact strength [N/m <sup>2</sup> ]	impact energy [%], impact energy [J]
Units	SI, metric, imperial	J, ft lbf, %
Control functions	friction and friction correction, vertical position of pendulum, time of swing	Friction and friction correction, vertical position of pendulum, time of swing
Correction functions	kinetic air and bearing friction yoke energy (Impact tensile test)	kinetic air and bearing friction yoke energy (Impact tensile test)
Interfaces	RS 232, USB	none
Impulse resolution	0.09°	0.09°
Electrical connection	100 to 240 V, 50/60 Hz, 70 W	100 to 240 V, 50/60 Hz, 70 W
Item number	•010917	•010920

#### HIT5P - installation, operator protection

The HIT5P can be installed on any sturdy and stable table with adequate stiffness in the pendulum impact direction.

However, we strongly recommend fixing the table top to a solid wall, e.g. with angle brackets. This is the only way to ensure no loss of energy when installing the tester on free-standing tables which would otherwise result in excessively high impact strength values.

Alternatively, the tables specifically designed for the HIT pendulum impact testers, starting at the HIT5.5P can be used.

The HIT5P can, according to current machine safety regulations, be operated without a safety device. However, a safety device is to be recommended if there is a risk of injury to the operator from specimen fragments.

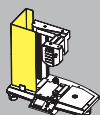

#### Safety device, left

fixed mounting on the left

•010924

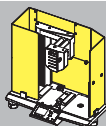

#### Safety device, fixed mounting left and right

Operating area freely accessible  
CE- and DIN 51233-compliant

•010926

## HIT5P - testXpert® II PC-Software

testXpert® II comprises Master and Standard Test Programs for optional use with the PC model.

### testXpert® II Test Programs

Master Test Program for pendulum impact tests: connects Zwick Roell pendulum impact testers with the functions required for the pendulum impact tester configuration in use	•377008
Standard Test Programs:	
to DIN 50115, pendulum impact test on metal	•377090
to DIN 53435 (Dynstat) pendulum impact tests on plastics	•377032
to ISO 179-1 (Charpy), ISO 180 (Izod), ISO 8256 (tensile impact) pendulum impact test on plastics	•377034
to ISO 179-2 06/2000, determination of Charpy impact properties on plastics, instrumented impact test	•377222
to ASTM D 6110 (Charpy), ASTM D 256, ASTM D 4812 (Izod), ASTM D 1822	•377036

### HIT5P – Charpy testing: pendulums

ISO 179 recommends using a pendulum in a narrowly limited range with the consequence is that pendulums must be changed quite often.

In order to meet this demand, HIT-pendulum impact testers have a pendulum quick-change unit. Pendulum changing is performed in seconds and, thanks to pendulum identification technology, without any further inputs.



Important: The HIT5P does not require additional pendulum masses or fasteners to change pendulum energy.

The combination of pendulum identification and the quick-change unit ensures that errors in pendulum energy due to incorrect use of supplementary masses or the loss of associated fasteners are eliminated.

Pendulums can be purchased individually or in sets:

Standard	Impact energy	Pendulum	Impact velocity
ISO 179-1	0.5 J	•010930	2.9 m/s
	1 J	•010932	2.9 m/s
	2 J	•010940	2.9 m/s
	4 J	•010941	2.9 m/s
	5 J	•010943	2.9 m/s

### HIT5P - Charpy testing: Charpy fixture and accessories

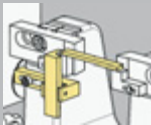

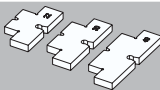

		
<b>Charpy fixture</b>	<b>Local operator shield and notch alignment unit</b>	<b>Side alignment unit</b>
•010961	•014988	•010965

## HIT5P - Charpy testing: jigs

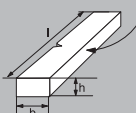
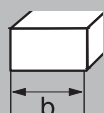

For adjustment of the anvils and adjustment of the fin to the anvils. The notch alignment unit can also be precisely adjusted.

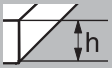
	
<b>Jig to ISO 179</b>	<b>Set of jigs to DIN 51222 and DIN 50115</b>
For adjustment of anvil span spacing to 60 mm	For adjustment of anvil span to 22, 30 and 40 mm
•016126	•016124

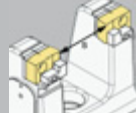
## HIT5P - Charpy testing: adapter plates, supports and anvils

						
<b>Standard</b>	<b>Size b</b>	<b>Adapter plate</b>	<b>Size h</b>	<b>Support</b>	<b>Anvil</b>	<b>Span</b>
ISO 179-1	10 mm 4 mm 15 mm 10 mm 3 mm 3 mm	•010945 •010947 - •010945 •010951 •010951	4 mm 10 mm 3 mm 3 mm 15 mm 10 mm	•325730 •325734 •325728 •325728 •325736 •325734	•010955 •010955 •010958 •010958 •010958 •010958	62 mm 62 mm 22 ... 70 mm 22 ... 70 mm 22 ... 70 mm 22 ... 70 mm
DIN 50115	4 mm	•010947	3 mm	•325728	•010958	22 ... 70 mm

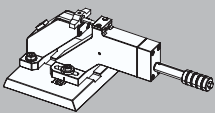
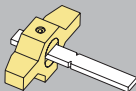
## HIT5P - tensile impact testing: tensile impact fixtures, yokes and pendulums

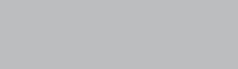
					
<b>Standard</b>	<b>Tensile impact fixture</b>	<b>Yoke</b>	<b>Mass</b>	<b>Impact energy, pendulum</b>	<b>Impact velocity</b>
ISO 8256-A	•010967	•325684 •325686	15 g 30 g	2 J 4 J	•010968 •010970 2.9 m/s 2.9 m/s

## HIT5P - tensile impact testing: clamping units for tests to ISO 8256

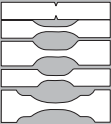
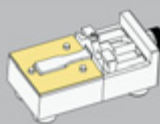
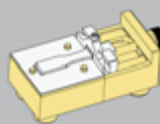
			
<b>Standard</b>	<b>Specimen type</b>	<b>Clamping template</b>	<b>Clamping jig</b>
ISO 8256 Method A	Type 1 Type 2 Type 3 Type 4	•325672 •325674 •325676 •325678	•325798

## 4. Instrument Specification HIT5.5P

The following points should be checked before a pendulum impact tester is specified in detail:

- To be used with or without a PC
- Standards to be used
- Test methods and specimen to be used

### Selection of HIT5.5P basic unit

	PC model	Stand Alone model
	to be used with PC	to be used without PC
Max. impact energy	5.5 J (4.06 ft lbf)	5.5 J (4.06 ft lbf)
Impact velocity	2.2 to 3.40 m/s	2.2 to 3.40 m/s
Interfaces	RS232, USB upstream	none
Height x Width x Depth (w/o shield)	920 x 870 x 500 mm	920 x 870 x 500 mm
Weight without accessories	approx. 137 kg	approx. 137 kg
Line voltage	100 to 240 V, 50/60 Hz, 70 W	100 to 240 V, 50/60 Hz, 70 W
Test results, numeric	impact energy [%], Impact energy abs. impact strength	impact energy [%], Impact energy abs.
Units	SI, metric, imperial	J, ft lbf, %
Control functions	friction correction vertical position of pendulum period of oscillation display of instrument data	friction correction vertical position of pendulum period of oscillation display of instrument data
Item number	•325650	•325648

### Pendulum release units for various standards

Two cable release units are available. The cable release unit is suitable for general purpose testing, and the pneumatic version is recommended for high specimen throughput.

In order to achieve the different impact speeds for ISO and ASTM tests, two starting angle mechanisms are available. They release the pendulum at the corresponding starting angle. To run tests to both groups of standards, please specify both item numbers.

Pneumatic release unit	Cable release unit	Starting angle according to DIN/ISO-Standards	Starting angle according to ISO/ASTM-Standards
		DIN 53435, ISO 179, ISO 8256	ISO 180, ASTM D6110, ASTM D256, ASTM D4812, ASTM D1822
•325700	•325702	•325924	•325926





### HIT5.5P - Instrumentation

This option is required for the instrumented Charpy and Izod pendulums.

Instrumentation	
For simple upgrading of a HIT basic instrument (PC model).	•021759
Date data recording unit enabling, for example, recording of a load signal during impact test	
Features of the data recorder:	
- High performance A/D converter with 16 bit resolution	
- Two independent, configurable data channels	
- Measurement frequency up to 4 MHz per channel	
- Ratiometric measurement ensures maximum measurement accuracy	
- Memory depth up to 200.000 data points per channel	
- Independently programmable trigger methods (e.g. angle of rotation)	

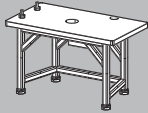
## HIT5.5P – installation, operator protection, pendulum brake

These items are optional.

			
Instrument table	Safety device left	Safety device left and right	Pendulum brake
Low vibration mount. table 1200 (47.3") x 710 (28"), weight: 115 kg	Swivable with specimen remains container, not required for energies $\leq 5.5$ J	Swivable left with remains container, fixed to the right. Operating area freely accessible CE- and DIN 51233-conform	Specimen disc brake, manually operated
•326058	•325816	•325818	•325704

## HIT5.5P - testXpert® II PC software

testXpert® II comprises Master and Standard Test Programs for optional use with the PC model.

testXpert® II Test Programs	
Master Test Program for pendulum impact tests: connects Zwick Roell pendulum impact testers with the functions required for the pendulum impact tester configuration in use	•377008
Standard Test Programs:	
to DIN 50115, pendulum impact test on metal	•377090
to DIN 53435 (Dynstat) pendulum impact tests on plastics	•377032
to ISO 179-1 (Charpy), ISO 180 (Izod), ISO 8256 (tensile impact) Pendulum impact test on plastics	•377034
to ISO 179-2 06/2000, determination of Charpy impact properties on plastics, instrumented impact test	•377222
to ASTM D 6110 (Charpy), ASTM D 256, ASTM D 4812 (Izod), ASTM D 1822	•377036

## HIT5.5P – Charpy testing: Charpy fixture and accessories

A local operator shield is optionally available for the Charpy fixture. Charpy supports and anvils are also available to suit the specimen.

The notch alignment unit is required to align the specimen notch with the centre of impact. If the distance from the edge of the notch to one end of the specimen is specified in the test Standard then the side alignment unit should be used for centering the specimen. The attached stop can be swivelled.

			
Charpy fixture	Local operator shield	Notch alignment unit	Side alignment unit
•325708	•325710	•325712	•325714

## HIT5.5P – Charpy testing: pendulums, pendulum-sets



ISO 179 recommends using a pendulum in a narrowly limited range with the consequence that pendulums must be changed quite often.

In order to meet this demand, HIT-pendulum impact testers have a pendulum quick-change unit. Pendulum changing is performed in seconds and, thanks to pendulum identification, without any further inputs.

Important: The HIT5.5P does not require additional pendulum masses or fasteners to change pendulum energy.

The combination of pendulum identification and the quick-change unit ensures that errors in pendulum energy due to incorrect use of supplementary masses or the loss of associated fasteners are eliminated.

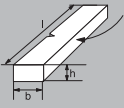
Pendulums can be purchased individually or in sets:

Standard	Impact energy	Conventional pendulum	Instrumented pendulum	Impact velocity
ISO 179-1 (conventional)	0.5 J	•325738	-	2.9 m/s
ISO 179-2 (instrumented)	1 J	•325740	-	2.9 m/s
	2 J	•325742	•021764	2.9 m/s
	4 J	•325744	-	2.9 m/s
	5 J	•325746	•021768	2.9 m/s
ASTM D 6110	0.5 J (0.37 ft lbf)	•325762	-	3.46 m/s
	1 J (0.74 ft lbf)	•325764	-	3.46 m/s
	2.7 J (2 ft lbf)	•325766	•021781	3.46 m/s
	5.4 J (4 ft lbf)	•325768	•021782	3.46 m/s
<b>Pendulum sets</b>				
ISO 179-1	4 J and 5 J	•325748	-	
ASTM D 6110	2.7 J and 5.4 J (2 ft lbf and 4 ft lbf)	•325770	-	

## HIT5.5P - Charpy testing: jigs



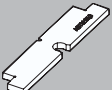
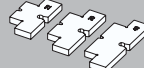

For adjustment of the anvils and adjustment of the tup to the anvils. The notch alignment unit can also be precisely adjusted.

Jig to ISO 179	Jig to ASTM D 6110	Set of jigs to DIN 51222 and DIN 50115
For adjustment of anvil span to 60 mm	For adjustment of anvil span to 95.3 mm	For adjustment of anvil span to 22, 30 and 40 mm
•016126	•016131	•016124

## HIT5.5P – Charpy testing: adapter plates, supports and anvils

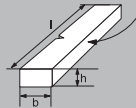
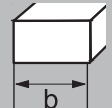
'Size b' in the table means the specimen's dimension in direction of impact, 'size h' is the dimension in the direction of the pendulum's center of rotation.

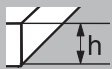
 Standard	 Size b	 Adapter plate	 Size h	 Support	 Anvil	 Span
ISO 179-1	10 mm	•325720	4 mm	•325730	•325716	62 mm
	4 mm	•325726	10 mm	•325734	•325716	62 mm
	15 mm	•325722	3 mm	•325728	•325718	22...70 mm
	10 mm	•325720	3 mm	•325728	•325718	22...70 mm
	3 mm	•325850	15 mm	•325736	•325718	22...70 mm
	3 mm	•325850	10 mm	•325734	•325718	22...70 mm
ASTM D 6110	12.7 mm (1/2")	•325752	3.17 mm (1/8")	•325754	•325750	101.6 mm (4")
	12.7 mm (1/2")	•325752	6.35 mm (1/4")	•325756	•325750	101.6 mm (4")
	12.7 mm (1/2")	•325752	12.7 mm (1/2")	•325758	•325750	101.6 mm (4")
DIN 50115	4 mm	•325726	3 mm	•325728	•325718	22...70 mm

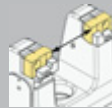
## HIT5.5P – Izod testing: fixtures

As the clamping force of the Izod fixture may directly influence the test results, two Izod fixtures are available:



The fixture with manual clamping transmits the torque to the jaws without friction loss, while the pneumatically operated fixture applies constant, adjustable clamping

pressure to the specimen. Operation is quick and easy via the integral pneumatic switch and is ideal for high volume testing

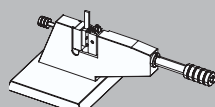
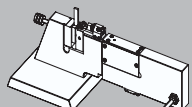
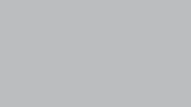
Inserts are required to accommodate the specimen to be tested.

		
<b>Izod fixture, manual</b> •325774	<b>Izod fixture, pneumatic</b> •325772	<b>Notch alignment unit</b> Contained in both

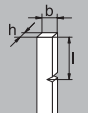
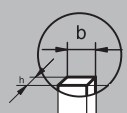
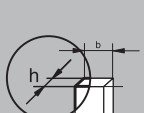
## HIT5.5P – Izod testing: inserts and pendulums

 Standard	 Specimen Size b	 Specimen Size h	 Insert	 Impact energy	Conventional pendulum	Instrumented pendulum
ISO 180	10 mm	4 mm	•325776	1 J (0.74 ft lbf)	•325786	
	10 mm	3 mm	•325778	2.75 J (2.03 ft lbf)	•325788	•021790
ASTM D 256	12.7 mm (1/2")	3.17 mm (1/8")	•325780	5.5 J (4.06 ft lbf)	•325790	•021792
ASTM D 4812	12.7 mm (1/2")	6.35 mm (1/4")	•325782	(pendulums can be used for all Standards)		
	12.7 mm (1/2")	12.7 mm (1/2")	•325784	Impact velocity: 3.46 m/s		



## HIT5.5P – tensile impact testing: tensile impact fixture, yokes and pendulums

Standard	Tens. impact fixture	Yoke	Mass	Impact energy, Pendulum	Impact velocity	
ISO 8256 Method A	•325682	•325684 •325686	15 g 30 g	2 J 4 J	•325688 •325690	2.9 m/s 2.9 m/s
ISO 8256 Method B	•325692	•325848	15 g	2 J 4 J	•325696 •325698	2.9 m/s 2.9 m/s
ASTM D 1822	•325692	•325848	15 g	1.35 J (1 ft lbf) 2.7 J (2 ft lbf) 5.4 J (4 ft lbf)	•325999 •325804 •325806	3.46 m/s 3.46 m/s 3.46 m/s

## HIT5.5P – tensile impact testing: clamping units for tests to ISO 8256 and ASTM D 1822

Simplifies effective clamping of the specimen in the yoke. Clamping template and jig are required.

Standard	Specimen type	Clamping template	Clamping gage
ISO 8256 Method A	Type 1 Type 2 Type 3 Type 4	•325672 •325674 •325676 •325678	•325798 (clamping jig can be used for all Standards)
ISO 8256 Method B	Type 2 Type 4	•325674 •325678	
ASTM D 1822	Type S / 9.53 mm (0.375") Type L / 9.53 mm (0.375") Type S / 12.71 mm (0.5") Type L / 12.71 mm (0.5")	•325800 •325802 •325950 •325952	

## HIT5.5P – Dynstat impact flexure testing: fixture and pendulum

Standard	Dynstat fixture	Impact energy, Pendulum	Impact velocity	
DIN 53435	•325808	0.2 J 0.5 J 1 J 2 J 4 J	•325948 •325810 •325812 •325814 •325996	2.2 m/s 2.2 m/s 2.2 m/s 2.2 m/s 2.2 m/s

## 5. Instrument Specification HIT25P / HIT50P

The following points should be checked before a pendulum impact tester is specified in detail:

- To be used with or without a PC
- Standards to be used

- Test methods and specimen to be used

Both impact testers already incorporate a two-hand safety pendulum release unit plus starting angles for tests to ISO and to ASTM.

### Selection of the HIT25P basic unit

	PC model	PC model with pendulum return	Stand Alone model
	to be used with PC	to be used with PC	to be used without PC
Max. impact energy	25 J (18.45 ft lbf)	25 J (18.45 ft lbf)	25 J (18.45 ft lbf)
Impact velocity	2.2 - 3.8 m/s	2.2 - 3.8 m/s	2.2 - 3.8 m/s
Interfaces	RS232, USB device	RS232, USB device	none
Height x Width x Depth (with shield)	1170 x 1180 x 500 mm	1170 x 1180 x 500 mm	1170 x 1180 x 500 mm
Weight w/o accessories	approx. 215 kg	approx. 225 kg	approx. 215 kg
Line voltage	100 to 240 V, 50/60 Hz, 70 W	100 to 240 V, 50/60 Hz, 70 W	100 to 240 V, 50/60 Hz, 70 W
Test results, numeric	impact energy [%], impact energy absolute impact strength	impact energy [%], impact energy absolute impact strength	impact energy [%], impact energy absolute
Units	SI, metric, imperial	SI, metric, imperial	J, ft lbf, %
Control functions	friction correction vertical position of pendulum period of oscillation display of instrument's data	friction correction vertical position of pendulum period of oscillation display of instrument's data	friction correction vertical position of pendulum period of oscillation display of instrument's data
Safety device	safety device left and right	safety housing	safety device left and right
Item number	•016889	•010892	•016892

### Selection of the HIT50P basic unit

The HIT50P requires a concrete base for floor mounting or use of instrument table 326104 necessary. Alternatively, a sufficiently stiff instrument table with a minimum weight of 260 kg may be used.

	PC model	PC model with pendulum return	Stand Alone model
	to be used with PC	to be used with PC	to be used without PC
Max. impact energy	50 J (36.90 ft lbf)	50 J (36.90 ft lbf)	50 J (36.90 ft lbf)
Impact velocity	2.2 - 3.8 m/s	2.2 - 3.8 m/s	2.2 - 3.8 m/s
Interfaces	RS232, USB device	RS232, USB device	none
Height x Width x Depth (with shield)	1170 x 1180 x 500 mm	1170 x 1180 x 500 mm	1170 x 1180 x 500 mm
Weight without accessories with instrument table	approx. 475 kg	approx. 500 kg	approx. 475 kg
Line voltage	100 to 240 V, 50/60 Hz, 70 W	100 to 240 V, 50/60 Hz, 70 W	100 to 240 V, 50/60 Hz, 150 W
Test results, numeric	impact energy [%], impact energy absolute impact strength	impact energy [%], impact energy absolute impact strength	impact energy [%], impact energy absolute
Units	SI, metric, imperial	SI, metric, imperial	J, ft lbf, %
Control functions	friction correction vertical position of pendulum period of oscillation display of instrument data	friction correction vertical position of pendulum period of oscillation display of instrument data	friction correction vertical position of pendulum period of oscillation display of instrument data
Safety device	safety device left and right	safety housing	safety device left and right
Item number	•016893	•010176	•016895

## HIT25P / HIT50P – installation, operator protection

These items are optional.

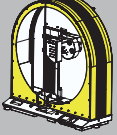
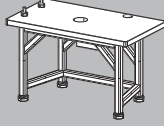
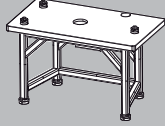
		
<b>Safety housing</b>	<b>Instrument table for HIT25P</b>	<b>Instrument table for HIT50P</b>
Covers entire front and top	Low-vibration mounting table with specimen tray Weight: 115 kg 1200 mm x 710 mm	Low-vibration mounting table with specimen tray Weight: 260 kg 1280 mm x 710 mm
•016674	•326058	•326104

## HIT25P / HIT50P - instrumentation

This option is required for instrumented Charpy and Izod pendulums.

Instrumentation	
For simple upgrading of a HIT basic instrument (PC model and PC model with return). Data recording unit enabling, for example, recording of a load signal during impact test. Features of the data recorder: - High performance A/D converter with 16 bit resolution - Two independent, configurable data channels - Measurement frequency up to 4 MHz per channel - Ratiometric measurement ensures maximum measurement accuracy - Memory depth up to 200.000 data points per channel - Independently programmable trigger methods: (e.g. angle of rotation)	•021759

## HIT25P / HIT50P - testXpert® II PC software

testXpert® II Master and Standard Test Programs are optionally available for the use with the PC model.

testXpert® II Test Programs	
Master Test Program for pendulum impact tests: connects Zwick Roell pendulum impact testers with the functions required for the pendulum impact tester configuration in use	•377008
Standard Test Programs:	
to DIN 50115, pendulum impact test on metal	•377090
to DIN 53435 (Dynstat) pendulum impact tests on plastics	•377032
to ISO 179-1 (Charpy), ISO 180 (Izod), ISO 8256 (tensile impact) Pendulum impact test on plastics	•377034
to ISO 179-2 06/2000, determination of Charpy impact properties on plastics, instrumented test method	•377222
to ASTM D 6110 (Charpy), ASTM D 256, ASTM D 4812 (Izod), ASTM D 1822	•377036

## HIT25P / HIT50P – Charpy testing: pendulums, pendulum sets

ISO 179 recommends using a pendulum in a narrowly limited range with the consequence that pendulums must be changed quite often.

In order to meet this demand, HIT pendulum impact testers have a pendulum quick-change unit. The changing of a pendulum is performed within seconds and, thanks to pendulum identification technology, without any further inputs.

Important: The HIT25P and HIT50P do not require additional pendulum masses or fasteners to change pendulum energy.

The combination of pendulum identification and the quick-change unit ensures that errors in pendulum energy due to incorrect use of supplementary masses or the loss of associated fasteners are eliminated.





Pendulums can be purchased individually or in sets:

Standard	Impact energy	Pendulum conventional	Pendulum instrumented	Impact velocity
ISO 179-1 (conventional)	0.5 J	•325738	-	2.9 m/s
ISO 179-2 (instrumented)	1 J	•325740	-	2.9 m/s
	2 J	•325742	•021764	2.9 m/s
	4 J	•325744	-	2.9 m/s
	5 J	•325746	•021768	2.9 m/s
	7.5 J	•326110	•021771	2.9 m/s
	15 J	•326112	•021776	3.8 m/s
	25 J	•326114	•021779	3.8 m/s
	50 J	•326116	•021780	3.8 m/s
ASTM D 6110	0.5 J (0.37 ft lbf)	•325762	-	3.46 m/s
	1 J (0.74 ft lbf)	•325764	-	3.46 m/s
	2.7 J (2 ft lbf)	•325766	•021781	3.46 m/s
	5.4 J (4 ft lbf)	•325768	•021782	3.46 m/s
	10.8 J (8 ft lbf)	•326118	•021784	3.46 m/s
	21.6 J (16 ft lbf)	•326120	•021785	3.46 m/s
<b>Pendulum sets</b>				
ISO 179-1	4 J and 5 J	•325748	-	
	15 J and 25 J	•016340	-	
ASTM D 6110	2.7 J and 5.4 J (2 ft lbf and 4 ft lbf)	•325770	-	

## HIT25P / HIT50P – Charpy testing: Charpy fixture and accessories

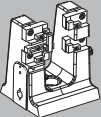

A local operator shield is optionally available for the Charpy fixture. Supports and anvils are additionally available to suit the specimen. The notch alignment unit is required to align the specimen notch with the centre of impact. If the distance from the edge of the notch to one end of the specimen is specified in the test

Standard, the side alignment unit should be used for centering the specimen. The attached stop can be swivelled. The side alignment unit can be mounted at any position (upper or lower impact level, right or left side) on the fixture. If frequent tests at different impact levels are performed it is advisable to fully equip the fixture for both tests.

			
<b>Charpy fixture</b>	<b>Local operator shield</b>	<b>Notch alignment unit</b>	<b>Side alignment unit</b>
•326106	•325710	•326108	•325714

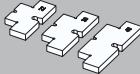

## HIT25P / HIT50P - Charpy testing: jigs

For adjustment of the abutments and adjustment of the tup to the abutments. The notch alignment unit can also be precisely adjusted.

		
<b>Jig to ISO 179</b>	<b>Jig to ASTM D 6110</b>	<b>Set of jigs to DIN 51222 and DIN 50115</b>
For adjustment of anvil span to 60 mm	For adjustment of anvil span to 95.3 mm	For adjustment anvil span to 22, 30 and 40 mm
•016126	•016131	•016124

## HIT25P / HIT50P – Charpy testing: adapter plates, supports and anvils

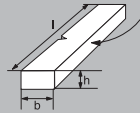
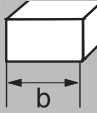
‘Size b’ in the table means the specimen’s dimension in direction of impact, ‘size h’ is the dimension in direction of the pendulum center of rotation. Each Charpy fixture should be equipped with adapter plates, supports and anvils.

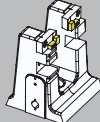
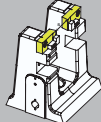
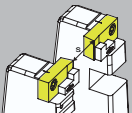
 Standard	 Size b	 Adapter plate	 Size h	 Support	 Anvil	 Span s
ISO 179-1	10 mm	•325720	4 mm	•325730	•325716	62 mm
	4 mm	•325726	10 mm	•325734	•325716	62 mm
	15 mm	•325722	3 mm	•325728	•325718	22...70 mm
	10 mm	•325720	3 mm	•325728	•325718	22...70 mm
	3 mm	•325850	15 mm	•325736	•325718	22...70 mm
	3 mm	•325850	10 mm	•325734	•325718	22...70 mm
ASTM D 6110	12.7 mm (1/2")	•325752	3.17 mm (1/8")	•325754	•325750	101.6 mm (4")
	12.7 mm (1/2")	•325752	6.35 mm (1/4")	•325756	•325750	101.6 mm (4")
	12.7 mm (1/2")	•325752	12.7 mm (1/2")	•325758	•325750	101.6 mm (4")
DIN 50115	4 mm	•325726	3 mm	•325728	•325718	22...70 mm

## HIT25P / HIT50P – Izod testing: fixtures

As the clamping force may directly influence the test results, two options are available:

The fixture with manual clamping transmits the torque to the jaws without friction loss, while the pneumatically operated fixture applies constant, adjustable clamping pressure to the specimen.

Operation is quick and easy via the integral pneumatic switch and is ideal for mass testing. Inserts are required to accommodate the specimen to be tested.

Each fixture must be fitted with the appropriate inserts.

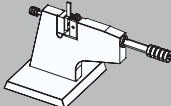
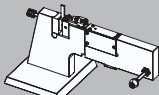
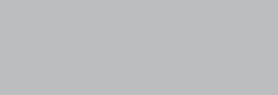
		
<b>Izod fixture, manual</b>	<b>Izod fixture, pneumatic</b>	<b>Notch alignment unit</b>
•326124	•326122	Contained in both

## HIT25P / HIT50P – Izod testing: inserts and pendulums



Standard	Specimen Size b	Specimen Size h	Insert	Impact energy	Conventional pendulum	Instrumented pendulum
ISO 180	10 mm	4 mm	•325776	1 J (0.74 ft lbf)	•325786	-
	10 mm	3 mm	•325778	2.75 J (2.03 ft lbf)	•325788	•021790
ASTM D 256	12.7 mm (1/2")	3.17 mm (1/8")	•325780	5.5 J (4.06 ft lbf)	•325790	•021792
				11 J (8.14 ft lbf)	•326126	•021794
ASTM D 4812	12.7 mm (1/2")	6.35 mm (1/4")	•325782	22 J (16.28 ft lbf)	•326128	•021802
	12.7 mm (1/2")	12.7 mm (1/2")	•325784	44 J (32.56 ft lbf)	•017324	•021803
				Pendulum set		
				11 J and 22 J	•016343	-
				(pendulums can be used for all Standards)		
				Impact velocity 3.46 m/s		

## HIT25P / HIT50P – tensile impact testing: tensile impact fixture, yokes and pendulums

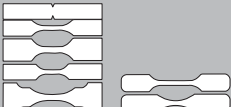

Standard	Tens. impact fixture	Yoke	Mass	Impact energy, pendulum	Impact velocity	
ISO 8256 Method A	•326241	•325684	15 g	2 J	•325688	2.9 m/s
	•326241	•325684	15 g	4 J	•325690	2.9 m/s
	•325682	•325686	30 g	7.5 J	•326132	3.8 m/s
	•325682	•325686	30 g	15 J	•326134	3.8 m/s
	•325682	•326140	60 g	25 J	•326136	3.8 m/s
	•325682	•326140	60 g	50 J	•326138	3.8 m/s
	•325682	•326245	120 g	25 J	•326136	3.8 m/s
	•325682	•326245	120 g	50 J	•326138	3.8 m/s
ISO 8256 Method B	•326130	•325848	15 g	2 J	•325696	2.9 m/s
	•326130	•325848	15 g	4 J	•325698	2.9 m/s
	•325692	•326247	30 g	7.5 J	•326142	3.8 m/s
	•325692	•326150	120 g	15 J	•326144	3.8 m/s
	•325692	•326150	120 g	25 J	•326146	3.8 m/s
•325692	•326150	120 g	50 J	•326148	3.8 m/s	
ASTM D 1822	•326130	•325848	15 g (0.033 lb)	1.35 J (1 ft lb)	•325999	3.46 m/s
	•326130	•325848	15 g (0.033 lb)	2.7 J (2 ft lb)	•325804	3.46 m/s
	•326130	•325848	15 g (0.033 lb)	5.4 J (4 ft lb)	•325806	3.46 m/s
	•326130	•326278	60 g (0.132 lb)	10.8 J (8 ft lb)	•326152	3.46 m/s
	•326130	•326278	60 g (0.132 lb)	21.6 J (16 ft lb)	•326154	3.46 m/s

## HIT25P / HIT50P – tensile impact testing: clamping units for tests to ISO 8256 and ASTM D 1822

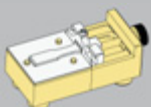
Simplifies a rectangular clamping of the specimen in the yoke. For this clamping template and jig are required.

 Standard	 Specimen type	 Clamping template	 Clamping jig
ISO 8256 Method A	Type 1 Type 2 Type 3 Type 4	•325672 •325674 •325676 •325678	•325798 (clamping jig can be used for all Standards)
ISO 8256 Method B	Type 2 Type 4	•325674 •325678	
ASTM D 1822	Type S / 9.53 mm (0.375") Type L / 9.53 mm (0.375") Type S / 12.71 mm (0.5") Type L / 12.71 mm (0.5")	•325800 •325802 •325950 •325952	

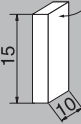
## HIT25P / HIT50P – Dynstat impact flexure testing: fixture and pendulum

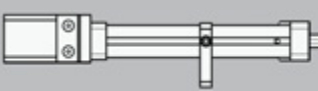
 Standard	 Dynstat fixture	 Impact energy, Pendulum	Impact velocity
DIN 53435	•326156	0.2 J •325948 0.5 J •325810 1 J •325812 2 J •325814 4 J •325996	2.2 m/s 2.2 m/s 2.2 m/s 2.2 m/s 2.2 m/s



---

**Zwick Roell AG**

August-Nagel-Str. 11  
D-89079 Ulm  
Phone ++49 7305-10-0  
Fax ++49 7305-10-200  
www.zwickroell.com  
info@zwickroell.com

**Zwick  
GmbH & Co. KG**

August-Nagel-Str. 11  
D-89079 Ulm  
Phone ++49 7305-10-0  
Fax ++49 7305-10-200  
www.zwick.com · info@zwick.de

**Toni Technik  
Baustoffprüfsysteme GmbH**

Gustav-Meyer-Allee 25  
D-13355 Berlin  
Phone ++49 30-46403921/23  
Fax ++49 30-46403922  
www.tonitechnik.com · info@tonitechnik.com

**Indentec  
Hardness Testing Machines Ltd.**

Lye Valley Industrial Estate, Bromley Street  
Lye, Stourbridge  
West Midlands DY9 8HX · Great Britain  
Phone ++44 1384-896949  
www.indentec.com · mail@indentec.demon.co.uk

**Acme Labo**

10/12 rue de l'Orme Saint Germain  
91160 Champlan · France  
Phone ++33 1-69 10 95 95  
Fax ++33 1-69 10 01 86  
www.acmel.fr · info@acmel.fr

**Zwick Asia Pte Ltd.**

25 International Business Park  
#04-17 German Centre  
Singapore 609916 · Singapore  
Phone ++65 6 899 5010  
Fax ++65 6 899 5014  
www.zwick.com.sg  
info@zwick.com.sg

**Zwick Testing Machines Ltd.**

Southern Avenue  
Leominster, Herefordshire HR6 OQH  
Great Britain  
Phone ++44 1568-61 52 01  
Fax ++44 1568-61 26 26  
www.zwick.co.uk  
sales.info@zwick.co.uk

**Zwick USA**

1620 Cobb International Boulevard  
Suite #1  
Kennesaw, GA 30152 · USA  
Phone ++1 770 420 6555  
Fax ++1 770 420 6333  
www.zwickusa.com  
info@zwickusa.com

**Zwick France S.a.r.l.**

B.P. 45045  
F-95912 Roissy CDG Cedex  
France  
Phone ++33 1-48 63 21 40  
Fax ++33 1-48 63 84 31  
www.zwick.fr  
info@zwick.fr

**Zwick Ibérica  
Equipos de Ensayos S.L.**

Marcus Porcius, 1  
Pol. Les Guixeres, s/n Edificio BCIN  
08915 Badalona (Barcelona) - Spain  
Phone ++34 934 648 002  
Fax ++34 934 648 048  
www.zwick.es  
comercial@zwick.es