



Salt Spray Corrosion Test Cabinets

Salt Spray Corrosion Cabinets



Model SF/450

Salt Spray Cabinets - SF Range

C&W cabinets are widely used to test both components and coated test panels across the whole spectrum of industry. The design ensures that they meet or exceed the requirements laid down in all major national, international and corporate standards. Pioneering designs have made C&W the UK leader in the manufacture of accelerated corrosion and environmental test cabinets.

The C&W salt spray range maintains this tradition being designed to deliver the precise environmental test conditions demanded by industry today. Through their reliability, ease of operation and robust construction, C&W salt spray cabinets have gained worldwide acceptance with applications in all major sectors of automotive manufacture as well as the paint, surface and coatings, chemical, electronics, aerospace, military and offshore industries.

Design Benefits

All C&W cabinets with their clean, functional design are manufactured from high quality materials selected specifically for this application:

- > Specially formulated fire retardant glass reinforced polyester (GRP) with high chemical and temperature tolerance – ivory white in colour.
- > Corrosion resistant construction throughout.
- > Low maintenance units.
- > Apex lids are formed in a range of composite materials depending on test requirements and supported by gas springs to ensure smooth operation and an effective seal when closed. Fully insulated.
- > Ergonomically designed control panel.
- > Over-temperature protection – factory set.
- > Transportation in areas of restricted access is made easier due to the compact design aided by removable lids and base frames.



Model SF/100

Standards and Accreditation

BRITISH/ISO/EN STANDARDS: BS.EN.ISO 7253, BS 3900 F12, BS 3900 F4, BS 2011 Part2:1 ka, BS EN 60068.2-52 kb, BS 5466, BS 7479, BS 3900 F18, ISO 20340, ISO 11 997, ISO 9227, ISO 3768. **GERMAN STANDARDS:** DIN 50.021, VG 95332/4, VG 95210/2. **AMERICAN STANDARDS:** ASTM B117, ASRM D5894, ASTM G85 (1,2,3+5), ASTM B368, SAE J2334. **FRENCH STANDARDS:** NFX 41-002, CT.UOI OIA, NFA 91-101, PNX 14-002. **JAPANESE STANDARDS:** JIS Z 2371, JIS H 8502, JASCO M 6009. **CORPORATE STANDARDS:** Ford, Jaguar, Land Rover, G.M, Toyota, Honda, Nissan, Renault, Peugeot, Citroen, Volvo, VW, Audi, BMW.

Optimum Operation

Effective corrosion testing requires close operational control and total accuracy. In C&W's salt spray cabinets these criteria are assured by:

- > MOBILE EXTERNAL SALT SOLUTION RESERVOIR with integral filter systems. 114 litre capacity, giving up to 14 days continuous operation depending on model size. Optional low level alarm system available. Easy access for filling and sterilisation to prevent excessive growth of algae.
- > ACCURATE SALT SOLUTION FLOW CONTROL via a variable speed, heavy duty peristaltic pump and flowmeter. This ensures precise collection rates and eliminates blockage.
- > FLOWMETER to accurately monitor salt solution flow.
- > SOPHISTICATED LUCITE ATOMISER for baffle free mist generation ensuring precise fallout throughout the chamber.
- > AIR REGULATOR and GAUGE to control and monitor the air pressure required for precise salt spray distribution.
- > SAMPLE RACKS are supplied as standard to accept panels or suspend samples.

Precise Control:

- > CABINET TEMPERATURE CONTROL: "Soft touch" waterproof membrane keypad control panel with user friendly tactile keypads giving full digital test display.
- > RANGE Ambient to 55°C. +/- 1°C.
- > TEMPERATURE CONTROL by N.T.C. Sensor.
- > HUMIDIFIER: Automatic self filling humidifier tower for compressed air saturation and heating with digital display of temperature set point. Range: Ambient to 65°C +/- 1°C. Tower includes incoloy heater, over temperature protection and air diffusers to create bubble formation of air within the tower to produce totally saturated and heated air. With low water level protection.
- > PROGRAMME CONTROL: The microprocessor controller has the capacity to store up to seven different test programmes.
- > CYCLE RUN and cycle left counter with end of test facility.
- > INTERMITTENT TEST FACILITY for spray/dry/air purge cycles.
- > Fully adjustable salt spray/dry cycles from continuous and 0 to 9999 minutes.
- > AIR PURGE: to remove corrosive air borne salt prior to sample inspection. This can be done manually or it can be included in a program to work automatically

Cabinet Variants

C&W manufactures a wide range of corrosion cabinets including conventional salt spray cabinets, cyclic Prohesion cabinets, CASS cabinets, combination salt spray/humidity cabinets and combination salt spray/ Prohesion-humidity cabinets.

> Combination salt spray/cyclic Prohesion cabinets SF/MP RANGE

These cabinets perform both standard salt spray and cyclic Prohesion® functions independently, an ideal solution when space is at a premium and test requirements do not justify separate test cabinets for each function.

> CASS Cabinets SF/CASS RANGE

Developed to carry out all standard salt spray and high temperature CASS tests typically employed when corrosion testing chrome plating on steel and plastic.

> Prohesion® MP RANGE

Prohesion® cabinets, originally developed by C&W, simulate natural weathering and provide a realistic method of accelerated corrosion testing for heavy duty industrial, marine and structural steel coatings.

> Combination salt spray/humidity cabinets SF/AB RANGE

This variant operates as a standard salt spray cabinet but with the added benefit that it can be switched on to operate as a humidity cabinet. When in the salt spray mode all given standards can be achieved. In humidity mode the cabinet will operate between 30°C and 80°C with a constant RH of 95-100% saturation.

Technical Specification

Optional Accessories

- > Low reservoir alarm.
- > External salt fog collection vessels.
- > Salt fog condenser venting system.
- > Compressor – available for continuous use or stand-by function: high specification, oil free.
- > Compressor switch – for automatic switch-over to stand-by or regular air supply.
- > De-ioniser & water filters – recommended for areas with hard water or high total dissolved solids (50mg/litre TDS).
- > Entry ports – for cable access to monitoring equipment or power induction.
- > Special racking – to support components/samples in test areas as required.

Cabinet Type	Salt Spray Cabinets					
Models	SF/100 100 litre	SF/200 200 litre	SF/450 450 litre	SF/1000 1000 litre	SF/2000 2000 litre	
Style	Bench Mounted	Floor Mounted				
External Dimensions	L	1000mm	1030mm	1370mm	1960mm	2400mm
	W	600mm	700mm	930mm	1335mm	1200mm
	H	645mm	1050mm	1130mm	1410mm	1645mm
Internal Dimensions	I	600mm	610mm	825mm	1465mm	2000mm
	W	450mm	510mm	635mm	1040mm	1000mm
	H ¹	375mm	455mm	620mm	720mm	850mm
	H ²	565mm	660mm	875mm	1065mm	1175mm
Panel Capacity	72	80	132	344	516	
Power Supply Amp	13	13	13	20	3 Phase 380 V 50/60Hz	
Compressed Air	TYPE: Clean, dry, oil free PRESSURE: 30 to 60 psi (2 to 4 BAR)			FLOW: 3.5cfm at 15 psi CONNECTION: 10mm ID plastic pipe		
Services	Power supply: 230 V 50/60Hz single phase other voltages available on request.					
Water	TYPE: De-ionised or mains water below 50mg/litre TDS PRESSURE: 30 to 60psi (2 to 4 BAR) CONNECTION: 10mm ID plastic pipe					
Drain	36mm outside diameter plastic pipe to liquid waste with air breather / vent pipe connected					
Salt Solution Reservoir With Lid	Supplied on castors with internal solution filter - 500mm x 620mm x 540mm (L x W x H)					

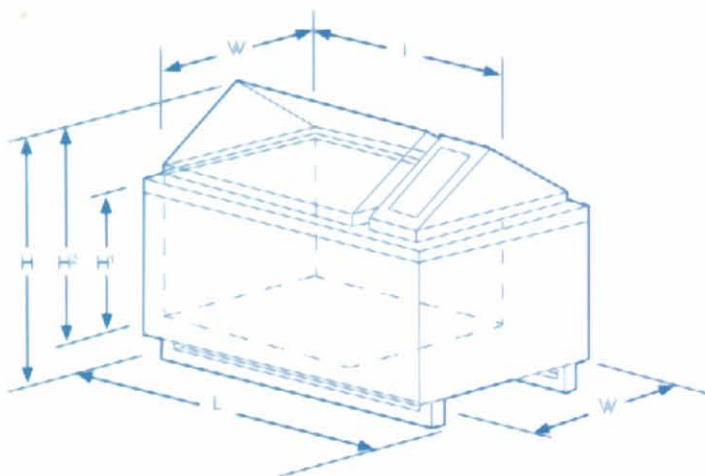

All cabinets are CE marked and have calibration traceable to UKAS. Certificates of Conformity are supplied on request. ISO 9001 Registered Company BSEN ISO 9001:2000. Subject to agreed maintenance procedures a two year warranty is available - generally UK only. The standard warranty is one year.

Due to continuous development we reserve the right to introduce improvements and /or modify specifications without prior notice.

Designed and printed in England Ref: 11-05-55